

2018 Waste Management Plan for Special Events

The City of Guelph prioritizes a three-stream waste collection program for recyclables, organics and garbage at special events. Please submit this Waste Management Plan at least **six (6) weeks** prior to when your event is scheduled. We will do our best to accommodate your request.

Please email the completed form to waste@guelph.ca.

Contact Information

Organization	
Organization Contact:	Name and Title:
	Email:
	Phone Number:
	Cell Phone Number:
Waste Diversion Liaison¹ Contact Information:	Name and Title:
	Email:
	Phone Number:
	Cell Phone Number:

1. The Waste Diversion Liaison is the key contact between the event and the Solid Waste Resources.

Event Information

Event name		
Event location		
Event type		
Event start date	Date:	Start time:
Event end date	Date:	End time:





# attendees expected	
# food vendors	
# merchandisers	
# portable washrooms (generating paper towel waste)	

Waste Information

Who will collect the waste generated?	<input type="checkbox"/> Private hauler (provide name):
	<input type="checkbox"/> City of Guelph (fill out request below)
	<input type="checkbox"/> Other (specify):
If using a private hauler, where will the material be sent?	Recyclables:
	Organics:
	Garbage:

Private haulers bringing organic waste to the City of Guelph Waste Resource Innovation Centre (WRIC) must be pre-approved under the Environmental Compliance Approval issued by the Ministry of Environment and Climate Change. Please notify your private hauler of this condition.

City of Guelph Waste Services Request

Please select cart sizes and note the quantities required			
 Blue Recycling carts	# Medium =	# Large =	# XL =
 Green Organics carts	# Medium =	# Large =	
 Grey Garbage carts	# Medium =	# Large =	# XL =
 Roll-off bins	14 yard =	40 yard =	

If requesting more than 10 carts please consider the use of a Roll-off bin.

The event organizer is responsible for the storage and security of any roll off bin(s) and cart(s) requested, waste sorting signs and waste station flags.

Drop off Date:	Pick up Date:	Drop-off Location:
-----------------------	----------------------	---------------------------

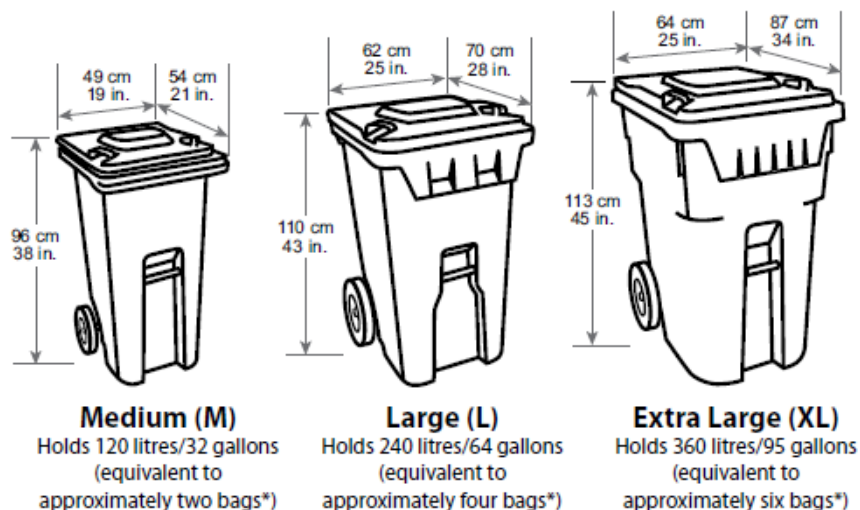

Waste Sorting Station Information

<p>Number of Stations <i>i.e. # Sets of blue, green and grey carts grouped together, with appropriate signage</i></p>			
<p>Number of Waste Volunteers</p>			
<p>Mandatory Staffing of Stations</p>	<p><input type="checkbox"/> I acknowledge that a minimum of one person/volunteer will staff each Waste Sorting Stations at all times to reduce contamination.</p>		
<p>Will vendors / merchandisers be permitted to use Stations? Not recommended</p>	<p><input type="checkbox"/> Not Available</p>		
<p>Previous event tonnages/ estimate of the amount of waste generated</p>	<p>Garbage:</p>		

Waste Diversion

<p>Have you established any waste policies for this event (e.g. paper plates, no Styrofoam, no plastic water bottles)? <input type="checkbox"/> Yes <input type="checkbox"/> No</p>
<p>If Yes, please describe:</p>
<p>How will you educate and train your volunteers?</p>
<p>How will you educate and train your vendors / merchandisers?</p>

Bag Requirements

GREY (garbage)	BLUE (recycling)	GREEN (organics)
<p>Items can be loose/un-bagged or in clear bags only.</p> <p>Black bags, white bags, grocery bags, and any non-clear bags are not accepted.</p>	<p>All items must be loose/un-bagged*</p>	<p>Items can be loose/un-bagged or in paper bags or certified compostable bags.</p> <p>Plastic bags are not accepted.</p>

*If you are using bags to line your blue carts at the Waste Sorting Stations and transferring this waste to a roll-off bin, please empty the bag contents loose into the recyclables roll-off bin. You can re-use the bags to line your blue carts and/or place them into the garbage roll-off bin once emptied.

2018 Fee Schedule

All fees will be invoiced to the Event Organizers once the event has been completed and all borrowed items have been returned.

Item	Fee	Cost per Damaged/Missing
Cart⁵	Free rental	\$52.00 per cart
Flag⁵	\$215.00 deposit per flag (max 5)	\$215.00 deposit is not returned
Banner or Sorting Sign⁵	Free rental (max 5 sets)	\$20.00 per sign and/or banner
Waste Collection Tipping Fee^{6,7}	Organics – Free	Not applicable
	Recyclables – Free	
	Garbage – \$80.00 per tonne or \$15.00 per cart	
Roll-off Bin	<ul style="list-style-type: none"> • \$90.00 per transfer to WRIC • \$150.00 for the bin rental • Applicable Tip fee 	Actual cost to repair or replace
Contamination Fee⁶	\$80.00 a tonne or \$15.00 per cart	Not applicable

⁵ Flags and signage are available on a first come, first serve basis. To avoid incurring fees, carts must be returned to the same location where the carts were initially delivered. Flags and signage must be returned undamaged to Solid Waste Resources within 24 hours after the event unless otherwise agreed upon.

⁶ Materials rejected for recycling or composting due to high rates of contamination (greater than 5% by visual inspection) will be sent to landfill, and the Event Organizers will be responsible for paying the garbage tip fee.

⁷ City waste collection is provided weekdays, Monday through Friday.

Thank you for supporting Guelph's waste diversion efforts