

# Post and Beam Connections

(to allow for future raising of deck in case of settlement)

## Beam to post connection:

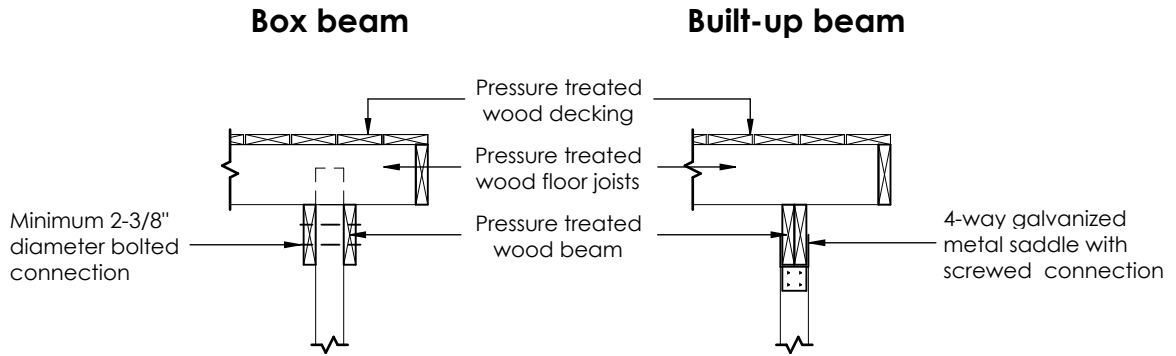

## Post to pier connection:

