

Deck – Guard System 1

Consult City of Guelph Building Services for any variance to design.

Exterior guards

For housing cantilevered picket screwed to rim joist. Reference 2024 Ontario Building Code: SB-7.

SIDE ELEVATION

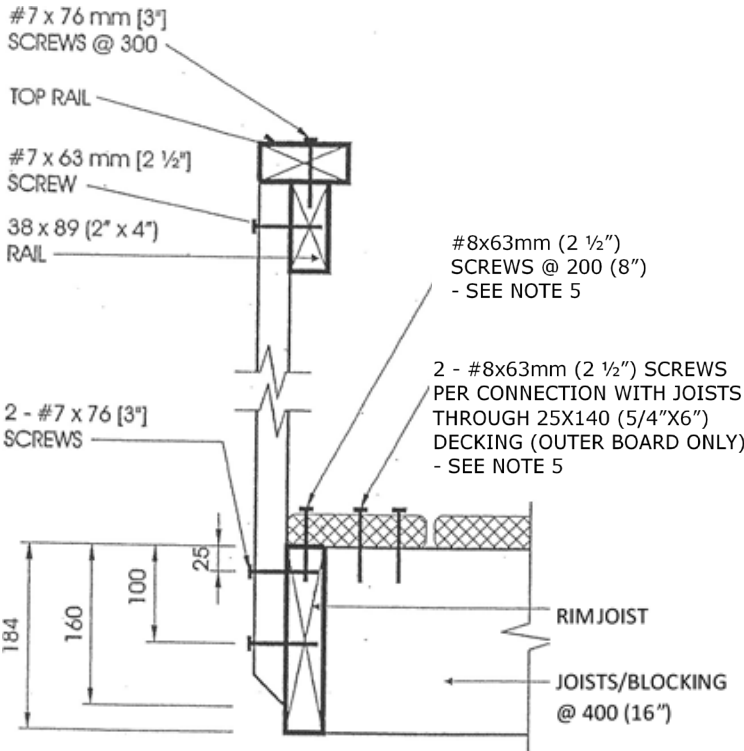

AXONOMETRIC

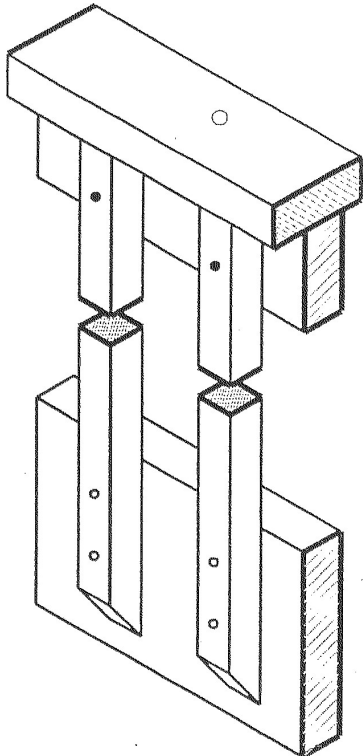

Notes:

1. Provide a suitable post, return or solid support at each end of the guard.
2. Wood for cantilevered pickets shall be Douglas Fir-Larch, Spruce-Pine-Fir, or Hem-Fir species.
3. Fasten rim joist to each floor joist with three 82 millimetre (1/4 inch) nails.
4. Dimensions shown are in millimetres unless otherwise specified.
5. The outer deck board must not be less than 140 millimetres (6 inch nominal) wide. Where 38 millimetre (2 inch nominal) thick boards are used, the length of the wood screws must not be less than 76 millimetres (3 inches).

Exterior guards

For housing post connection details – required at ends and corners of guard.
Reference 2024 Ontario Building Code: SB-7.

Option 1: Post screwed to rim joist

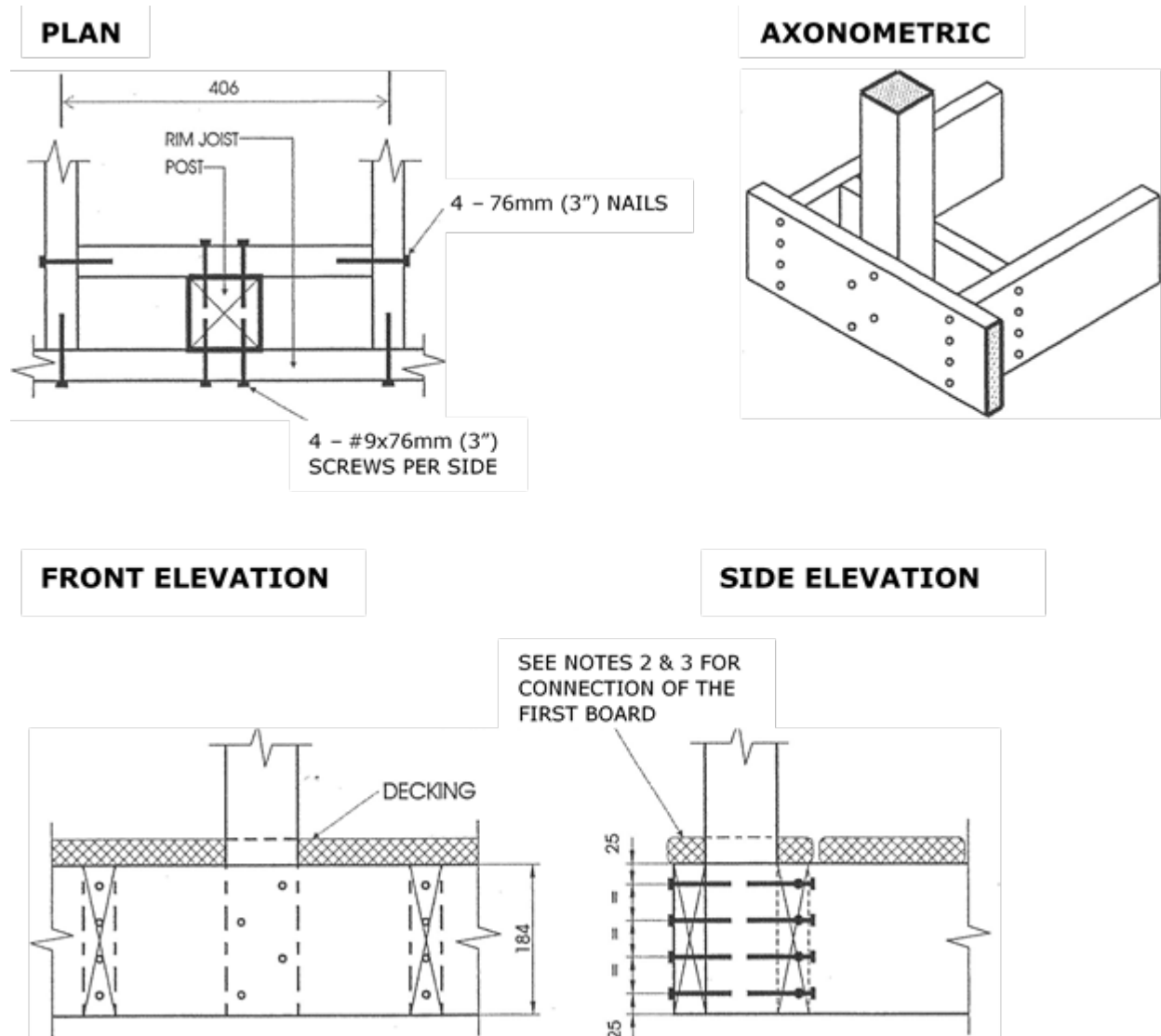

Notes:

1. Decking is omitted from the plan view and the axonometric view for clarity.
2. Fasten 25 millimetre by 140 millimetre (5/4 inch by 6 inch nominal) outer deck board to rim joist with 63 millimetre (2-1/2 inch) nails at 300 millimetres (12 inches).
3. Fasten 25 millimetre by 140 millimetre (5/4 inch by 6 inch) outer deck board to floor joist with one 63 millimetre (2-1/2 inch) nail at each joist.
4. The post may be positioned anywhere between the joists.
5. #9 screws may be replaced by #8 screws if the maximum spacing between posts is not more than 1.20 metres (3 feet-11 inches).

Option 2: Post bolted to floor joist (8 millimetres – 5/16 inch bolts)

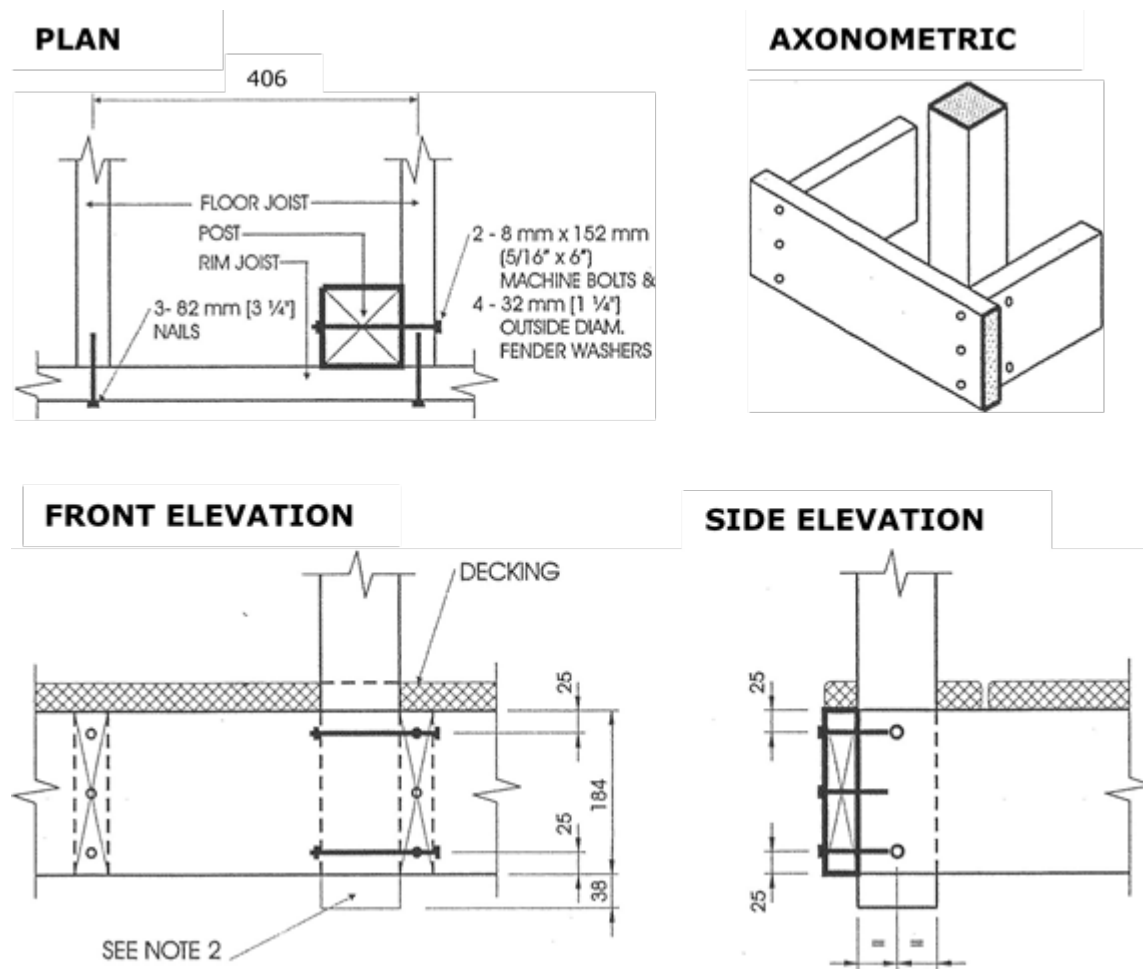

Notes:

1. Decking is omitted from the plan view and the axonometric view for clarity.
2. 38 millimetre (1-1/2 inch) post projection is not required where the maximum spacing between posts does not exceed 1.20 metres (3 feet-11 inches).
3. Joists may be spaced at 610 millimetres (24 inches) on centre or 406 millimetres (16 inches) on centre.
4. Where floor joists are spaced at 610 millimetres (24 inches) on centre, decking must have a minimum thickness of 38 millimetres (1-1/2 inches) and must be fastened to the floor with two 76 millimetre (3 inch) nails.

Option 3: Post fastened to floor, guard parallel to floor joists

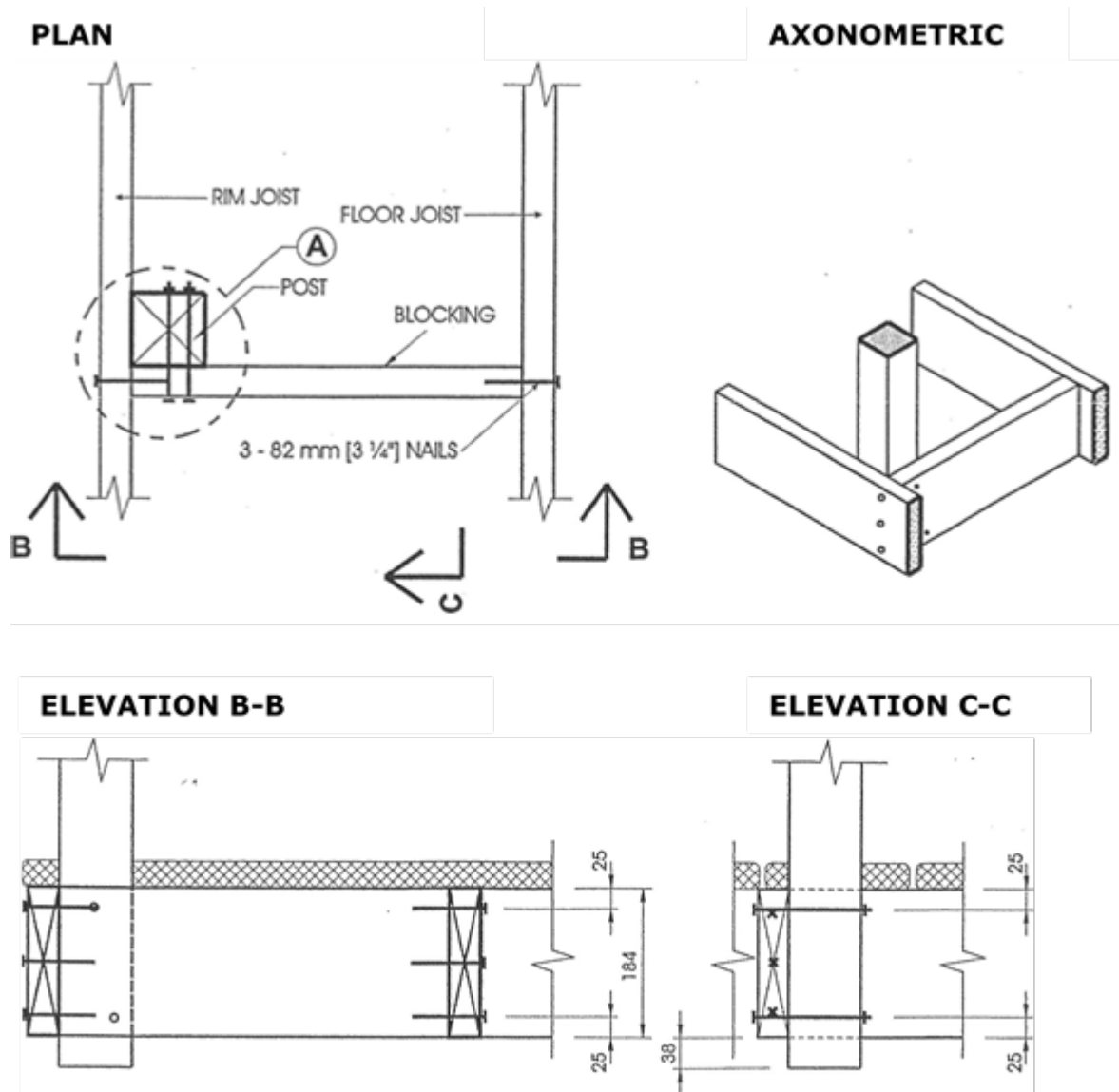

Notes:

1. Use any of the connection details shown on details EB-I to EB-5 at location A. Connection detail EB-4 is shown in this detail as an example.
2. Maximum spacing between posts is determined from connection detail used at location A.
3. Decking is omitted from the plan view and the axonometric view for clarity.
4. Blocking must not be less than 38 millimetres by 184 millimetres (2 inches by 8 inches nominal).

Alternate formats of this document are available as per the Accessibility for Ontarians with Disabilities Act by contacting Building Services at 519-837-5615 or email: building@guelph.ca.