

CLAIR RD E

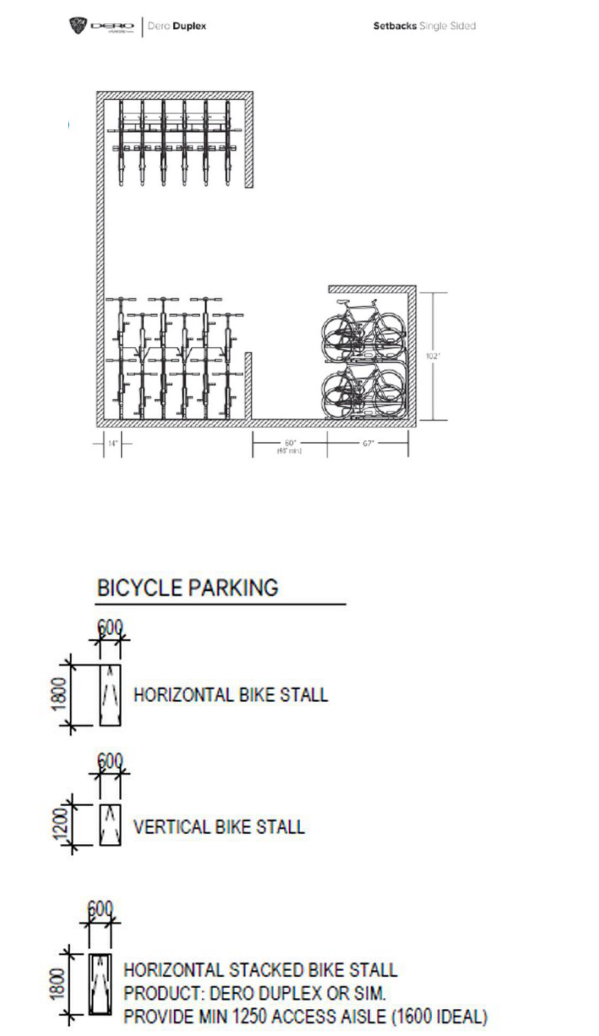
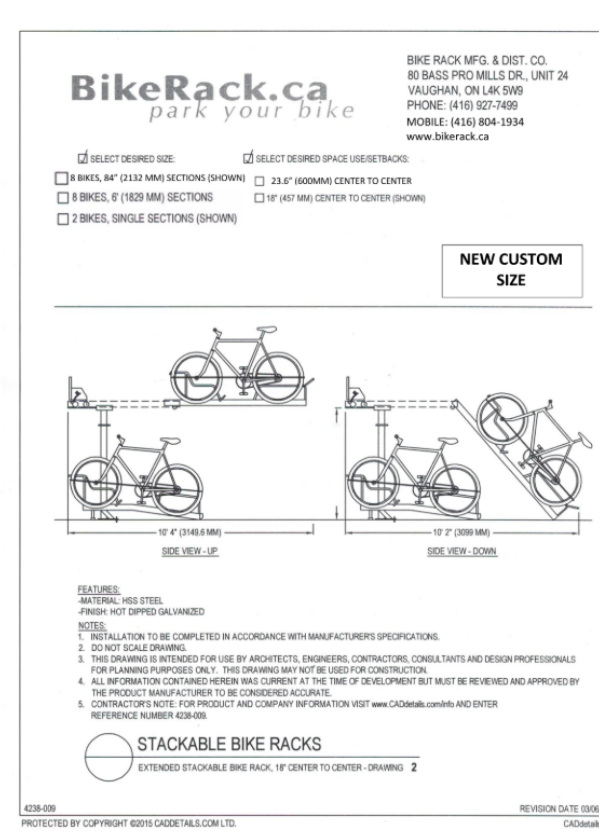
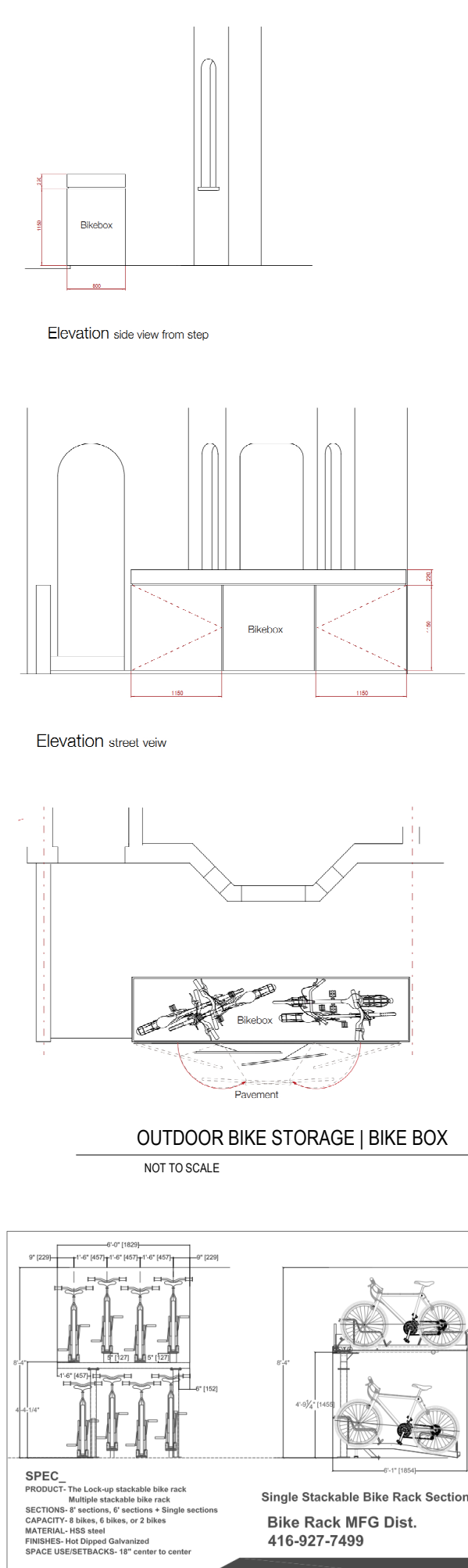

COPYRIGHT RESERVES THIS DESIGN AND DRAWINGS ARE THE EXCLUSIVE PROPERTY OF THE DESIGNER AND CANNOT BE USED FOR ANY PURPOSE WITHOUT THE WRITTEN CONSENT OF THE DESIGNER.
 THIS DRAWING IS NOT TO BE USED FOR CONSTRUCTION UNLESS VERIFIED FROM COMMENCEMENT OF THE WORK THE CONTRACTOR SHALL VERIFY ALL DIMENSIONS, DATA AND LEVELS TO IDENTIFY ANY ERRORS AND DISCREPANCIES AND REPORT ANY DISCREPANCIES BETWEEN THE DRAWING AND THE FIELD CONDITIONS TO THE DESIGNER IMMEDIATELY UPON THE DETECTION OF THE DISCREPANCY FOR CORRECTION.

NO.	DATE	REVISION / ISSUANCE
1	231215	Issued For ZBA Pre-Submission

NOTES

- GROUND FLOOR PLAN KEY NOTES:**
- LOADING SPACE HAS A LENGTH OF 11.4m, WIDTH OF 6m AND AN UNENCUMBERED VERTICAL CLEARANCE OF 6.5m. IS LEVEL (+/- 2%) AND IS CONSTRUCTED OF A MINIMUM 200mm REINFORCED CONCRETE.
 - STAGING AREA HAS AN UNENCUMBERED VERTICAL CLEARANCE OF 6.5m. IS CONSTRUCTED OF 200mm REINFORCED CONCRETE, AND HAS A SLOPE NO GREATER THAN 2%.
 - ALL ACCESS DRIVEWAYS USED BY WASTE COLLECTION VEHICLE WILL BE LEVEL (+/- 8%), HAVE A MINIMUM VERTICAL CLEARANCE OF 4.4m THROUGHOUT, A MINIMUM OF 4.5m WIDE THROUGHOUT, AND 6m WIDE AT INGRESS/EGRESS.
 - OVERHEAD DOORS THE COLLECTION VEHICLE WILL PASS THROUGH WILL HAVE A MINIMUM WIDTH OF 4m AND A VERTICAL CLEARANCE OF 6.5m.

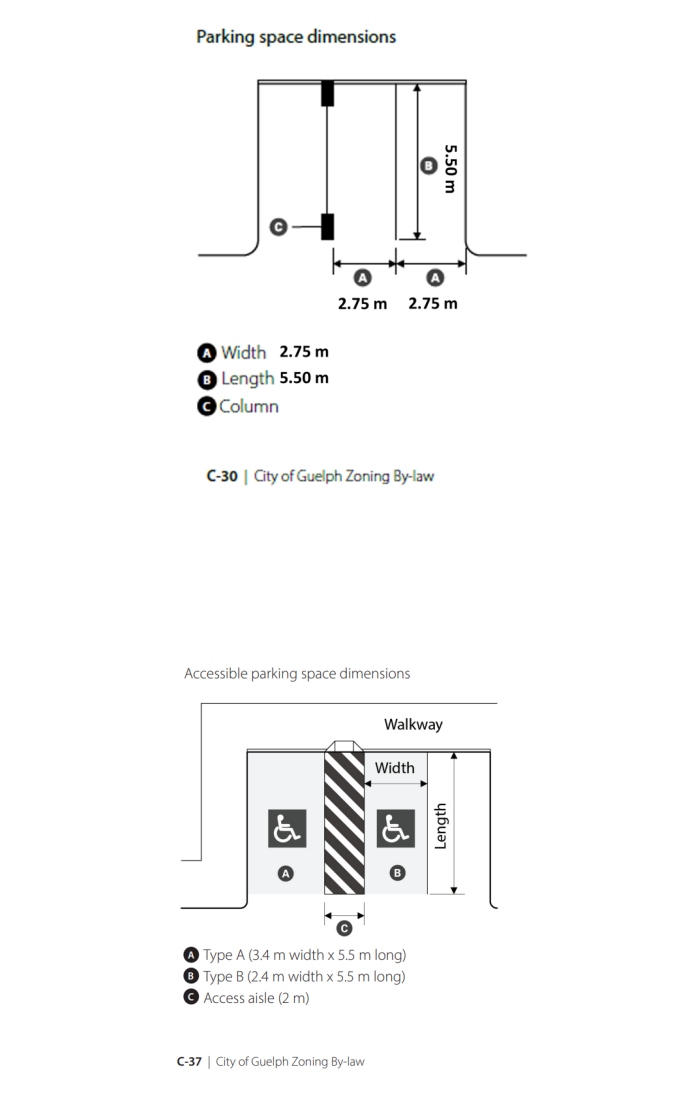

SvN ARCHITECTS
 100 BROADVIEW AVE. TORONTO, ONT. M5E 1B4
 TEL: 416-593-8888 FAX: 416-593-8889
 WWW.SVNARCHITECTS.COM

PERGOLA COMMONS

GROUND LEVEL PLAN

PROJECT	SCALE	DRAWN	AUTHOR
PERGOLA COMMONS	1:200	CHKD	CHKD
DATE		CHECKED	CHECKER
TU/06/23			

A 201
 2023-12-14 24:53 PM